

Video Cassette Player
Owner's Manual

VP115CAT



Read this manual first!

*Congratulations on purchasing this Philips product.
We've included everything you need to get started.
If you have any problems, Philips Representatives can
help you get the most from your new product by explaining:*

- Hookups,
- First Time Setup, and
- Feature Operation.

Do not attempt to return this product to the store.

**For fast help, call us first!
1-800-531-0039**

Thank you for making Philips a part of your home!

Let's make things better.



PHILIPS

Return your Warranty Registration card today to ensure you receive all the benefits you're entitled to.

Once your PHILIPS purchase is registered, you're eligible to receive all the privileges of owning a PHILIPS product. So complete and return the Warranty Registration Card enclosed with your purchase at once. And take advantage of these important benefits.

Warranty Verification

Registering your product within 10 days confirms your right to maximum protection under the terms and conditions of your PHILIPS warranty.

Owner Confirmation

Your completed Warranty Registration Card serves as verification of ownership in the event of product theft or loss.

Model Registration

Returning your Warranty Registration Card right away guarantees you'll receive all the information and special offers which you qualify for as the owner of your model.

PHILIPS

Congratulations on your purchase, and welcome to the "family!"

Dear PHILIPS product owner:

Thank you for your confidence in PHILIPS. You've selected one of the best-built, best-backed products available today. And we'll do everything in our power to keep you happy with your purchase for many years to come.

As a member of the PHILIPS "family," you're entitled to protection by one of the most comprehensive warranties and outstanding service networks in the industry.

What's more, your purchase guarantees you'll receive all the information and special offers for which you qualify, plus easy access to accessories from our convenient home shopping network.

And most importantly you can count on our uncompromising commitment to your total satisfaction.

All of this is our way of saying welcome-and thanks for investing in a PHILIPS product.

Sincerely,



Robert Minkhorst
President and Chief Executive Officer

P.S. Remember, to get the most from your PHILIPS product, you must return your Warranty Registration Card within 10 days. So please mail it to us right now!



Know these safety symbols



⚡ This "bolt of lightning" indicates uninsulated material within your unit may cause an electrical shock. For the safety of everyone in your household, please do not remove product covering.

⚠ The "exclamation point" calls attention to features for which you should read the enclosed literature closely to prevent operating and maintenance problems.

WARNING: TO PREVENT FIRE OR SHOCK HAZARD, DO NOT EXPOSE THIS EQUIPMENT TO RAIN OR MOISTURE.

CAUTION: To prevent electric shock, match wide blade of plug to wide slot, fully insert.

ATTENTION: Pour éviter les choc électriques, introduire la lame la plus large de la fiche dans la borne correspondante de la prise et pousser jusqu'au fond.

For Customer Use

Enter below the Serial No. which is located on the rear of the cabinet. Retain this information for future reference.

Model No. _____
Serial No. _____



PHILIPS

Visit our World Wide Web Site at <http://www.philips.com>

Welcome to your Video Cassette Player owner's manual. This manual has four sections: Setting Up Your VCP; Description of Controls; Operations; and Information You May Need. The instructions explain all of the VCP's features, which are listed below.

Features

- AC/DC Power System
- Automatic Head Cleaner
- Automatic Operation Features
- Automatic Tracking Adjustment
- Dew Sensor
- Display Panel
- Picture Control
- Remote Control
- Repeat Playback
- Special Effects Playback: Forward and Reverse Searching; Still

Safety Precautions

Warning: To prevent fire or shock hazard, do not expose this equipment to rain or moisture.

Federal Communications Commission (FCC) Warning: Any unauthorized changes or modifications to this equipment void the user's authority to operate it.

This VCP has a High Quality (HQ) system and is compatible with existing Video Home System (VHS) equipment. Philips Consumer Electronics recommends you use only video cassette tapes that have the **VHS** mark. The use of other tapes may result in poor picture quality and excessive deposits on the video heads, which may not be covered by the warranty if damage occurs.

Note to the Cable TV System Installer: This reminder calls the Cable TV system installer's attention to Article 820-40 of the National Electrical Code, which provides guidelines for proper grounding – in particular, specifying that the cable ground shall be connected to the grounding system of the building, as close to the point of cable entry as possible.

Moisture Condensation Warning: Moisture may condense inside the unit when you move it from a cold place to a warm place, after heating a cold room, or when the humidity is high. When moisture accumulates in your VCP, the POWER light will blink on the VCP and the  symbol will appear on the TV screen. If you try to play a tape in a VCP in which moisture has accumulated, the tape and the VCP could be damaged. If the POWER light is blinking, keep the VCP power on (but do not play a tape) for at least two hours. When the POWER light stops blinking, it is safe to play a tape.

Declaration of Conformity

Model Number: VP115CAT
Trade Name: Philips
Responsible Party: Philips Consumer Electronics
P.O. Box 14810
Knoxville, TN 37914-1810
(865) 521-4316

Copyright 2001 Philips Consumer Electronics. All rights reserved.

Helpful Hints

- Before doing anything else, record the VCP's model and serial numbers in the spaces on page two. These numbers will help us assist you if you ever call for help.
- Your new product, its packaging, and this manual contain materials that can be recycled and reused. Specialized companies can recycle your product to increase the amount of reusable materials and to minimize the amount that needs to be properly disposed. Your product uses batteries that should not be thrown away when depleted but should be disposed of as small chemical waste. Please find out about the local regulations on disposal of your old product, batteries, manual, and packaging whenever you replace existing equipment.

4 Table of Contents

Setting Up Your VCP

Introduction	3
Table of Contents	4
Before Using Your VCP	5
Hookups Without a Cable Box	6-7
Hookups With a Cable Box	8-9
Hookups With a Stereo TV	10
Mobile Connections	11

Description of Controls

Remote Control Buttons	12
Display Panel	13
Front Panel	14
Rear Panel	15

Operations

Playing	16
Repeat Playback	17
Picture Control	18
Playback Options	19
Automatic Operation Features	20

Information You May Need

Glossary	21
Helpful Hints	22-23
Limited Warranty	24-25
Specifications	26
Index	27
Accessories	28

Before Using Your VCP 5

Putting Batteries in the Remote Control

1

Remove the battery compartment lid on the bottom of the remote control by sliding the lid in the direction of the arrow.

2

Insert two AA batteries inside the battery compartment with their + and - ends aligned as indicated.

3

Replace the battery compartment lid.

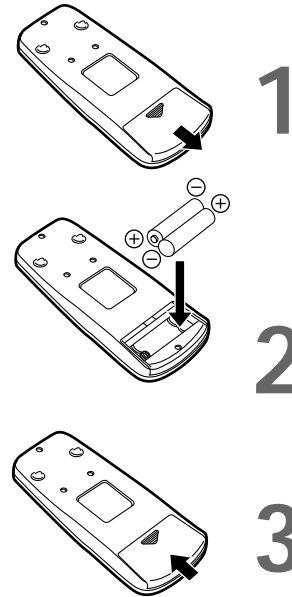

Using the Remote Control

- Point the remote control at the VCP's remote sensor when operating the VCP. *Details are on page 14.*
- Do not put objects between the remote control and the VCP.

Battery Usage CAUTION

To prevent battery leakage that may result in bodily injury or damage to the unit:

- Install ALL batteries correctly, with the + and - markings on the battery aligned as indicated on the unit.
- Do not mix batteries, for example, old with new or carbon with alkaline.
- Remove batteries when the unit will not be used for a long time.

VCP Maintenance

- Use only tapes with the **VHS** mark.
- Remove any light adhesive stick-on notes from the video cassette tape before putting the tape in the VCP. Removable labels can jam the VCP.
- The VCP requires periodic maintenance to maintain its excellent performance. This VCP has an Automatic Head Cleaner. However, the video heads will require replacement eventually. Only an authorized service center should perform this service.

Types of Video Cassette Tapes/Tape Speeds

The chart below shows the playback time for three types of video cassettes (T160, T120, and T60). There are three playback speeds: SP, LP, and SLP.

You can only play a tape in the speed in which it was recorded. You can not change the tape speed at the VCP.

The slower the tape speed, the more programming will fit on the tape. SLP is the slowest tape speed.

Tape Speed	Cassette type/Playback Time		
	T160	T120	T60
SP (standard play)	2 hrs. 40 mins.	2 hrs.	1 hr.
LP (long play)	5 hrs. 20 mins.	4 hrs.	2 hrs.
SLP (super long play)	8 hrs.	6 hrs.	3 hrs.

6 Hookups Without a Cable Box

The basic VCP/TV connection – antenna/cable to VCP to TV – is shown below. If you have a Cable Box, please refer to pages eight-nine. If you have a Stereo TV, please go to page 10. To use the VCP in an automobile, go to page 11.

1

Disconnect the antenna or cable from your TV.

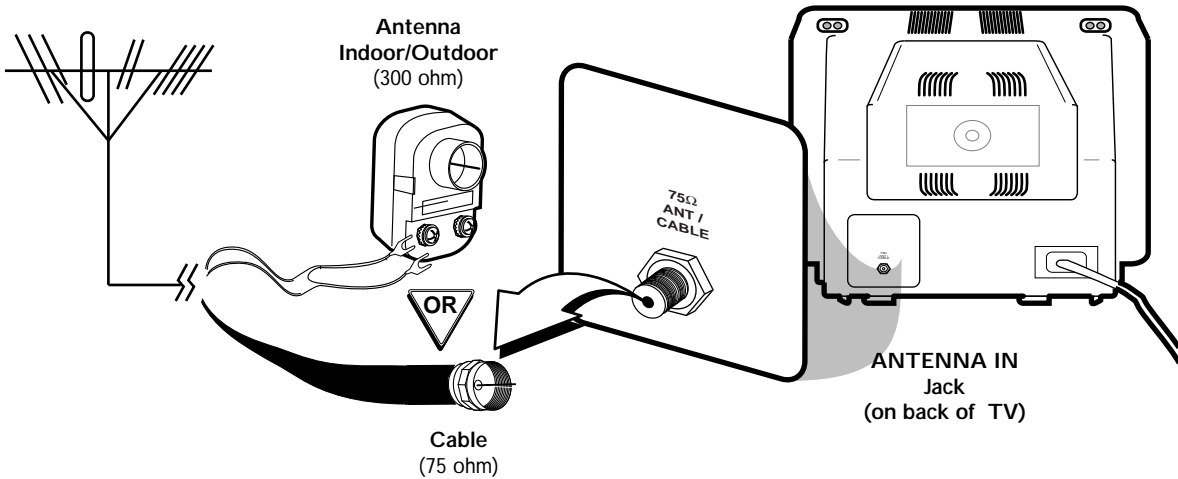

2

Connect the antenna or cable to the ANT(enna) IN jack of your VCP.

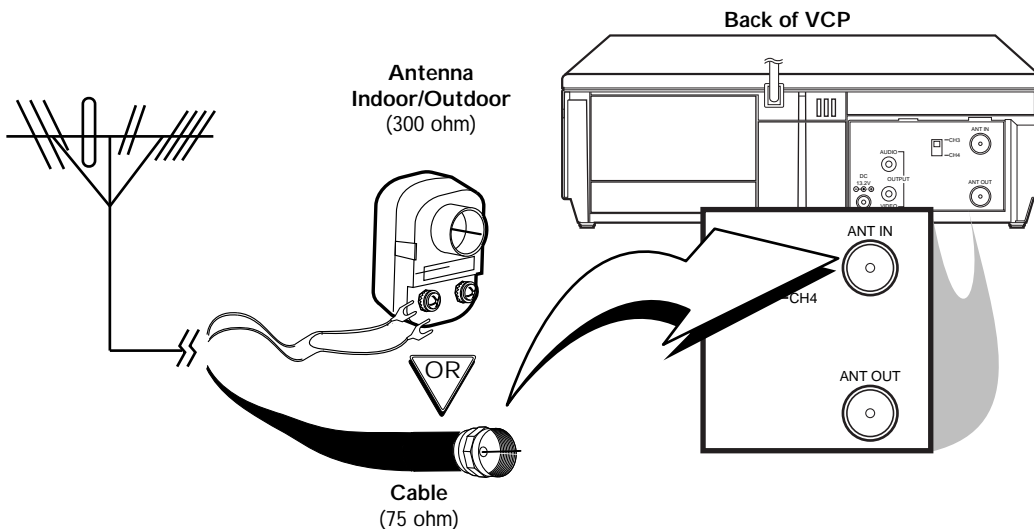

Hookups Without a Cable Box (cont'd) 7

3

Connect the RF coaxial cable (supplied) to the ANT(enna) OUT jack on the back of the VCP and to the ANTENNA IN Jack on the TV. (You may use either a snap-on type or screw-on type of coaxial cable, whichever you prefer. A snap-on type is supplied.)

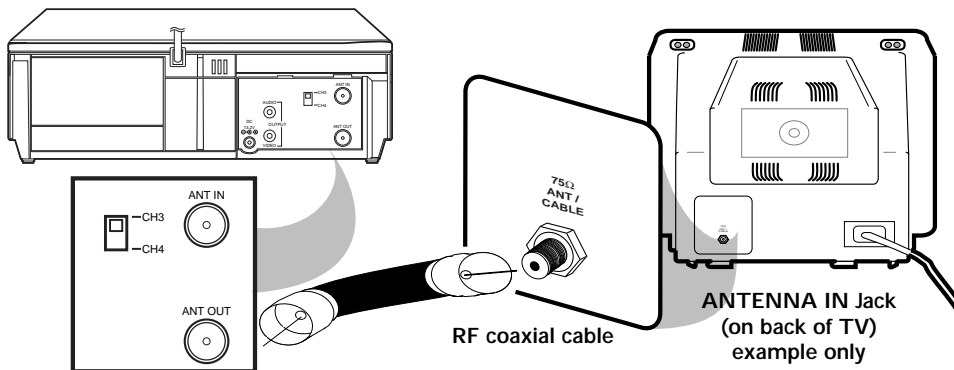

4

Plug in the power cords of the TV and the VCP.

5

Set the CH3/CH4 switch on the back of the VCP to CH3 or CH4, whichever channel is not used or least used in your area. To operate your VCP with your TV, **set the TV to the same channel**. For example, when playing a tape, if the CH3/CH4 switch is set to CH3, the TV should be on channel 3.

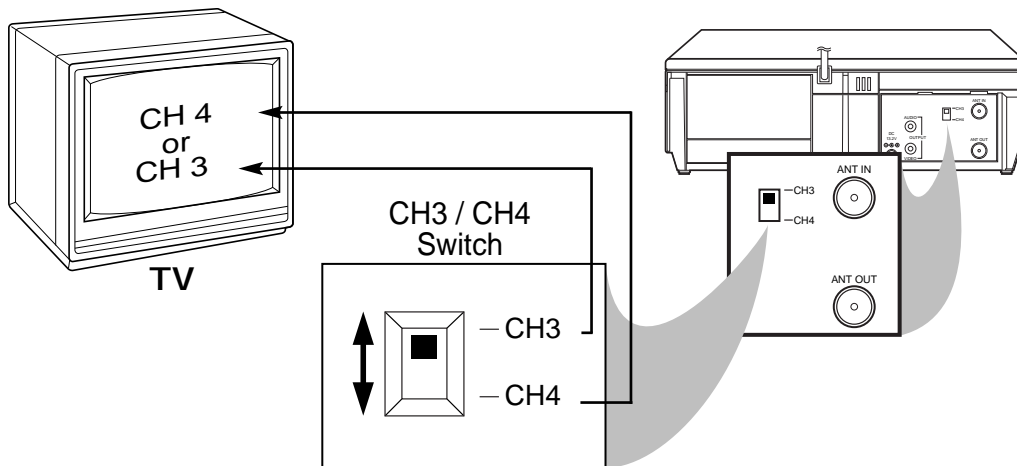

6

You are ready to turn on the VCP. Go to page 16 to play a tape.

8 Hookups With a Cable Box

This connection allows you to view any channel. You must select channels at the Cable Box.

1. Connect the Cable signal to the IN Jack on the Cable Box.

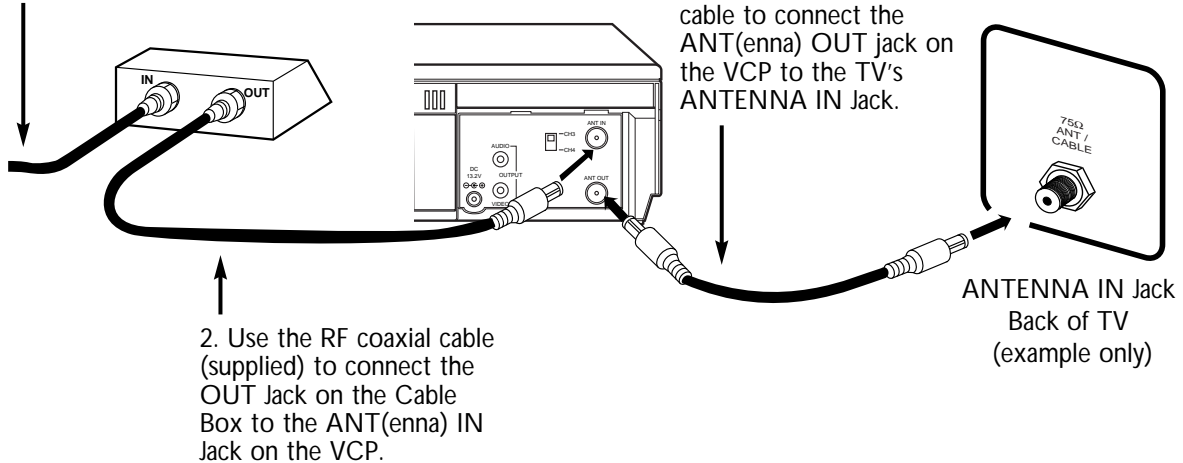

Watching TV with the VCP Off

1

Turn off the VCP power.

2

Turn on the TV and set it to the Cable Box output channel (channel 3 or 4).

3

Turn on the Cable Box and select the channel you want to watch at the Cable Box. You can not select channels at the TV.

Playing a Tape

1

Set the TV to channel 3 or 4, whichever channel the CH3/CH4 switch on the VCP is set to.

2

Turn on the VCP or insert a tape, if necessary. Press the PLAY button to play the tape. *Details are on page 16.*

Hookups With a Cable Box (cont'd) 9

This connection differs from the one shown on page eight. You may still view any channel (selecting channels at the Cable Box), but the instructions for playing a tape are different.

1. Connect a Cable signal to the VCP's ANT(enna) IN Jack.

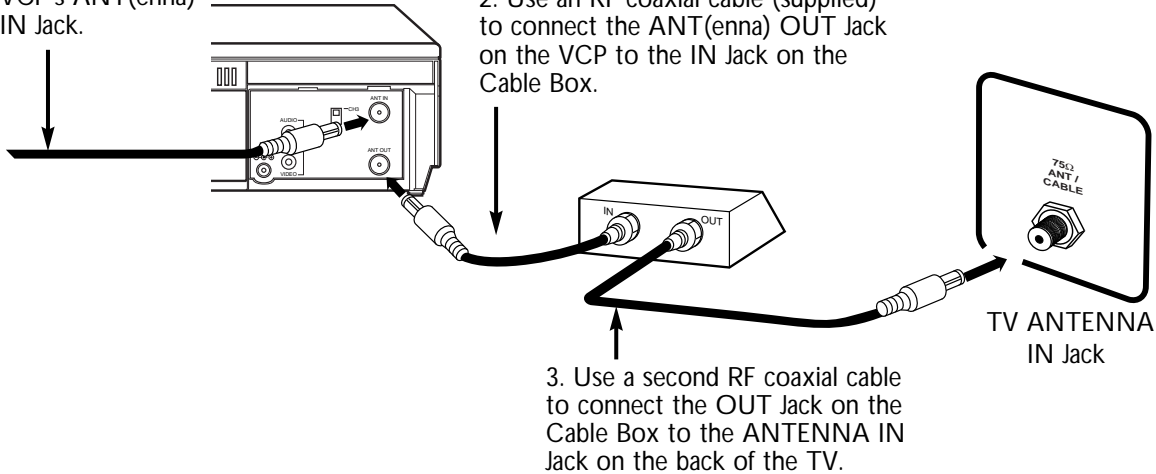

Watching TV with the VCP Off

1

Turn off the VCP.

2

Turn on the TV and set it to the Cable Box output channel (channel 3 or 4).

3

Turn on the Cable Box and select the channel you want to watch at the Cable Box.

Playing a Tape

1

Make sure the Cable Box is on the same channel as the VCP's CH3/CH4 switch.

2

Set the TV to the Cable Box output channel (channel 3 or 4).

3

Turn on the VCP or insert a tape, if necessary. Press the PLAY button to play the tape. *Details are on page 16.*

10 Hookups With a Stereo TV

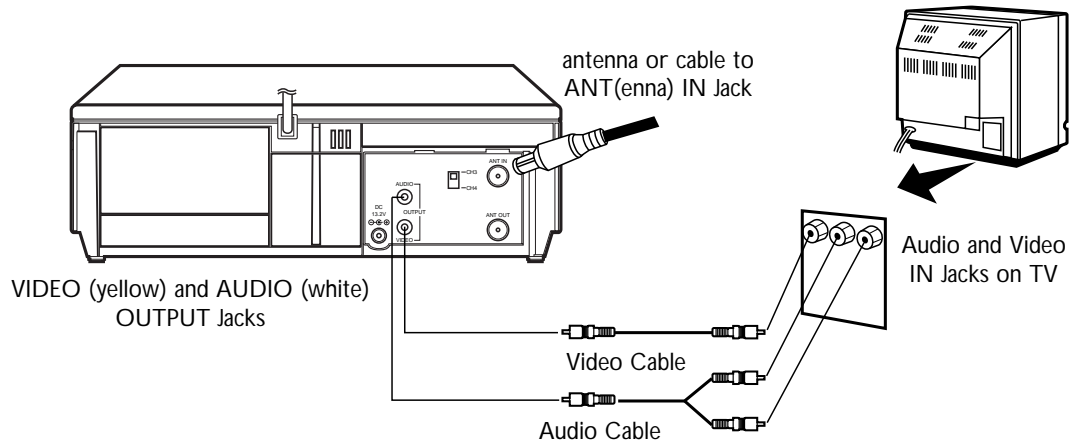

- Audio and Video cables are not supplied.

1

Connect the antenna or cable to the ANT(enna) IN Jack on the back of the VCP.

2

Connect a video cable to the yellow VIDEO OUTPUT Jack on the back of the VCP. Then, connect the other end of the video cable to the VIDEO IN Jack on your TV.

3

Connect an audio cable to the white AUDIO OUTPUT Jack on the back of the VCP. Then, connect the other end of the audio cable to the AUDIO IN Jack on your TV. (If your TV has Right and Left AUDIO IN Jacks, you must use a "Y" splitter audio cable as illustrated to deliver audio to the TV's left and right channels.)

4

Turn on your TV, making sure it is in Line Input mode. Your TV manual may refer to this as an Auxiliary In or Audio/Video In channel. Please refer to your TV owner's manual for details.

Helpful Hints

- This hookup will not give you stereo sound. To get stereo sound, use the connections on pages six-nine and select channels at the TV or the Cable Box (with the VCP off).
- You can also use the AUDIO and VIDEO OUTPUT jacks to connect the VCP to other equipment - such as a VCR if you want to copy tapes.

Mobile Connections 11

When passengers in your vehicle want to watch a video program, hook up the VCP by following the steps below. Do not start your vehicle until all connections are complete.

1

Make sure your vehicle has a 13.2-volt, negative ground electrical system. Unplug the AC power cords of the VCP and the TV.

2

Connect one end of the supplied car battery cord to the DC 13.2V jack on the back of the VCP.

3

Connect the other end of the car battery cord to the cigarette lighter jack in your vehicle.

4

Follow step 3 on page seven to connect the VCP to a TV.

5

Connect the TV to a DC power source. The TV must have an AC/DC jack.

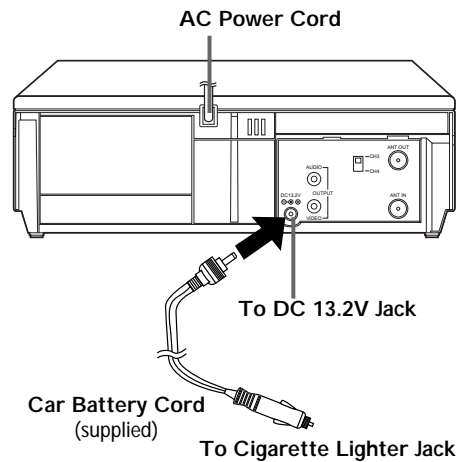

Fuse Replacement (Car Battery Cord)

If the VCP does not have power when connected properly in your vehicle, you may need to replace the fuse in the car battery cord.

Use only a 5-amp, 250-volt, fast blow fuse, which is available at an electronics retailer.

1

To remove the old fuse, unscrew the red cap from the end of the cord. Place your fingers on the grooved part of the cap and turn the cap counter-clockwise.



2

When the cap is removed, the red cap and the silver tip will be loose. The fuse will be loose inside the end of the cord.

3

Remove the old fuse and insert a new fuse.



4

Replace the red cap and the silver tip. The fuse will tighten into place as you screw on the cap, turning the cap clockwise. (The end of the fuse will fit into the silver tip, which is in the center of the red cap when tightened.)

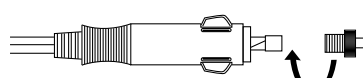

Helpful Hints

- Do not watch TV while driving.
- Use only the supplied car battery cord. Using another cord could damage the VCP or cause faulty operation.
- Make sure the cigarette lighter jack is free of ashes and other debris.
- Make sure you push the car battery cord's plug completely into the cigarette lighter jack.
- Always unplug the car battery cord from the cigarette lighter jack before you unplug it from the VCP.
- You must disconnect the car battery cord from the VCP before you can use standard AC electrical power.
- If the vehicle's engine is off, there will not be enough electrical voltage to operate the VCP.
- Unplug the car battery cord from the cigarette lighter jack when you have finished using the VCP.

12 Remote Control Buttons

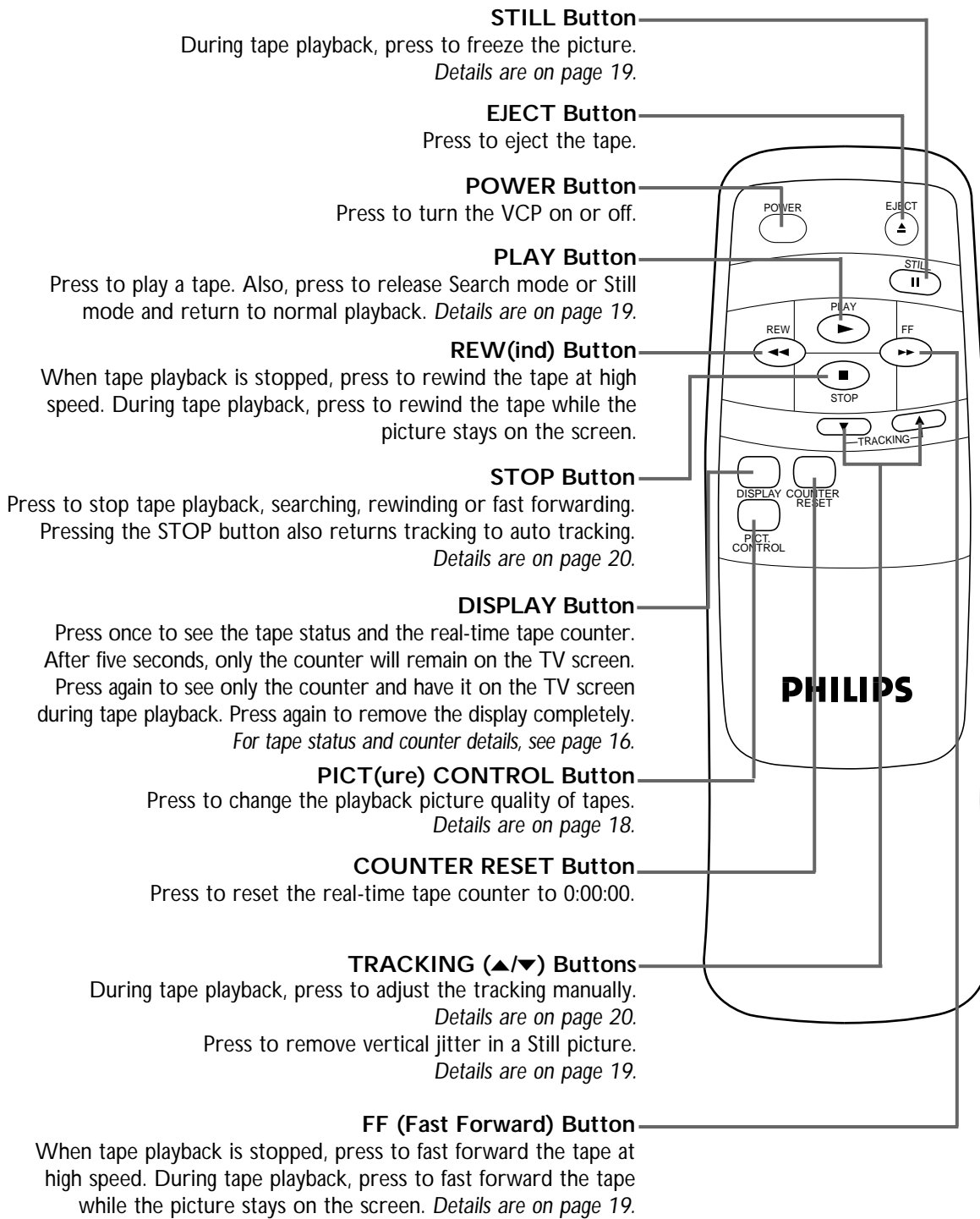

Display Panel 13

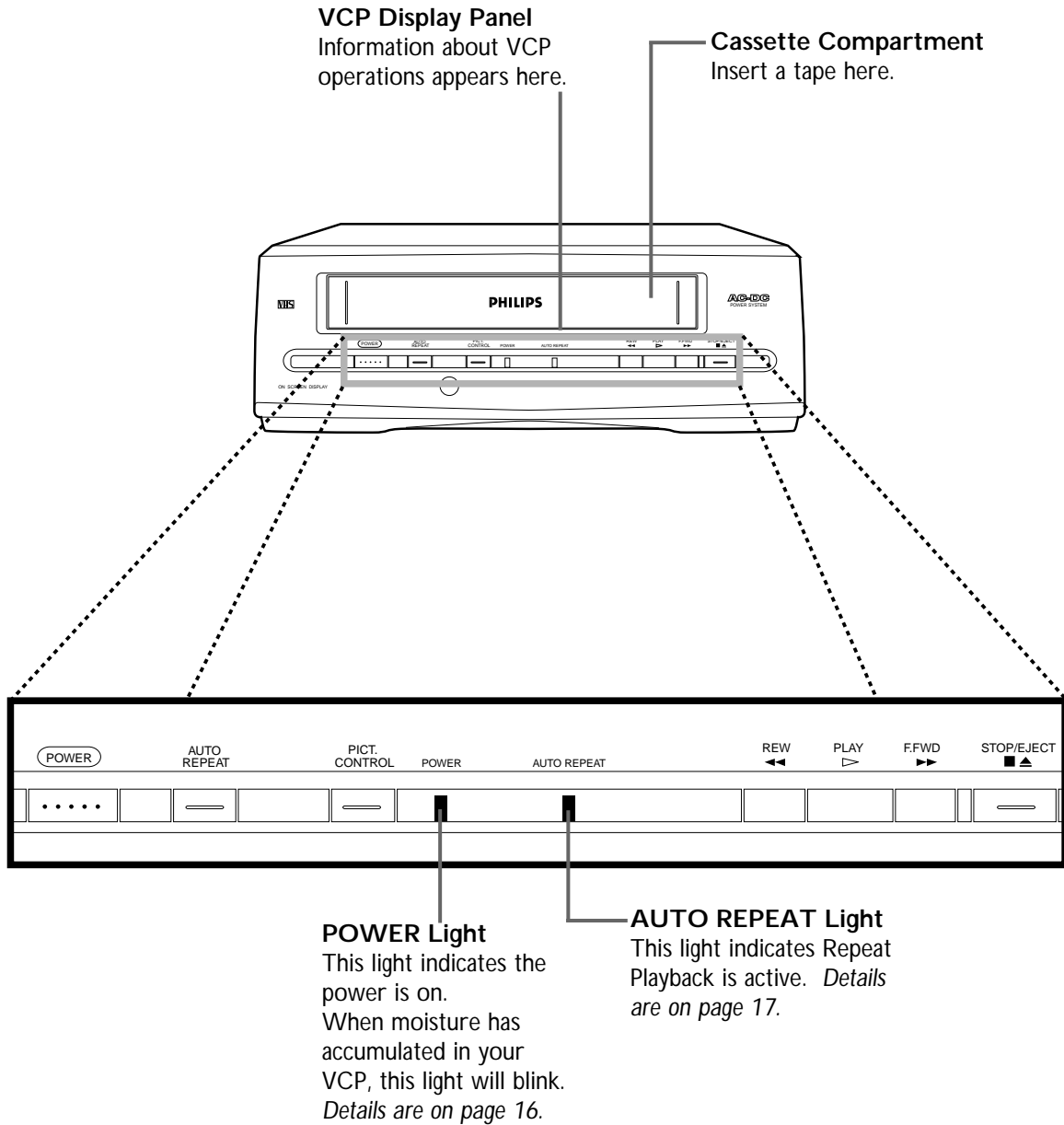

14 Front Panel

STOP/EJECT Button

Press once to stop the tape. When tape playback is stopped, press to eject the tape.

F.FWD (Fast Forward) Button

When tape playback is stopped, press to fast forward the tape at high speed. During tape playback, press to fast forward the tape while the picture stays on the screen. *Details are on page 19.*

PLAY Button

Press to play a tape. Also, press to release Search mode or Still mode and return to normal playback. *Details are on page 19.*

REW(ind) Button

When tape playback is stopped, press to rewind the tape at high speed. During tape playback, press to rewind the tape while the picture stays on the screen. *Details are on page 19.*

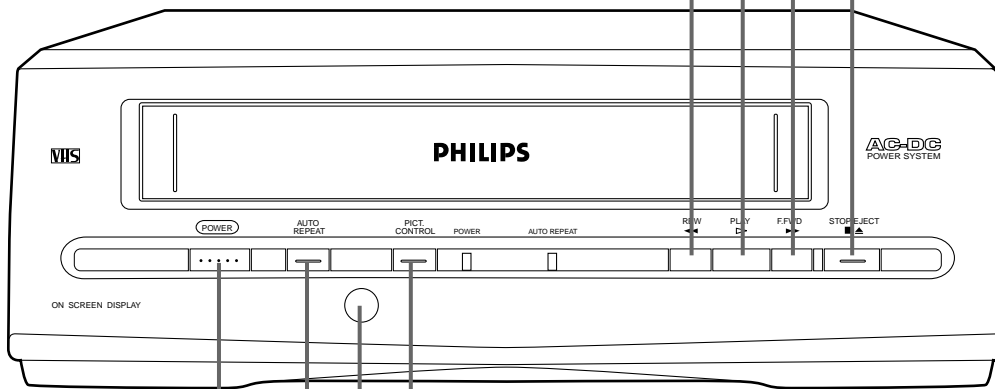

POWER Button

Press to turn the power on and off.

PICT(ure) CONTROL Button

Press to change the playback picture quality of tapes. *Details are on page 18.*

Remote Sensor

Receives the signal from your remote control so you can operate your VCR from a distance.

AUTO REPEAT Button

Press to make the VCR play a tape over and over. Press again to cancel Repeat Playback. *Details are on page 17.*

CH3/CH4 Switch

Set to channel 3 or 4 to use your TV with your VCP. *Details are on pages six-nine.*

AC Power Cord

Connect to a standard AC outlet to supply power to the VCP. Make sure the car battery cord is disconnected from the VCP.

ANT(enna) IN Jack

Connect your antenna, cable signal, or RF coaxial cable here. *Details are on pages six-10.*

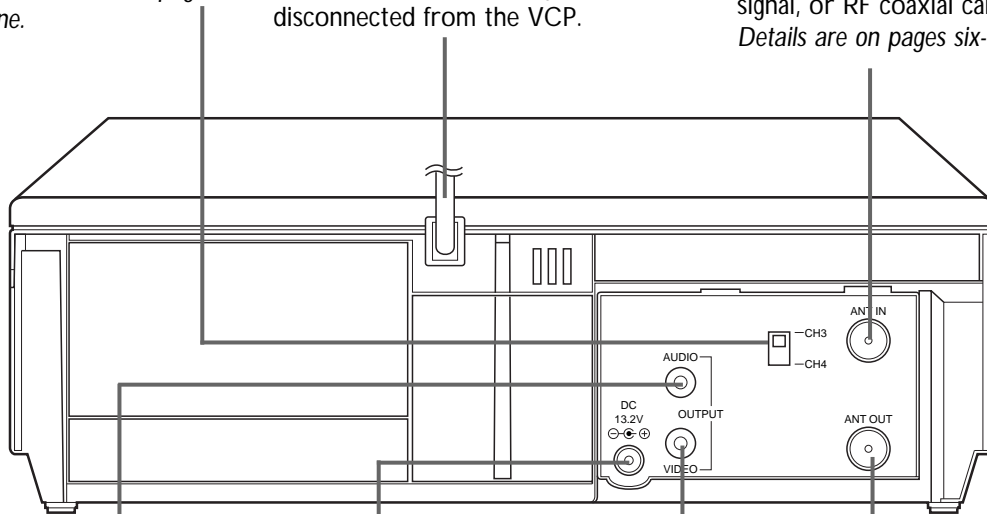

AUDIO OUTPUT Jack

Use an audio cable (not supplied) to connect this jack to the Audio In jack of a TV, camcorder, VCR, or audio system. *Details are on page 10.*

VIDEO OUTPUT Jack

Use a video cable (not supplied) to connect this jack to the Video In jack of a TV, camcorder, VCR, or monitor. *Details are on page 10.*

DC 13.2V Jack

Connect the car battery cord here when you use the VCP in your vehicle. *Details are on page 11.*

ANT(enna) OUT Jack

Use the supplied RF coaxial cable to connect this jack to the ANTENNA IN jack on your TV or Cable Box. *Details are on pages six-nine.*

16 Playing

Before playing a tape, make sure the VCP and TV are connected (see pages six-11). Then, follow the steps below.

1

Turn on the TV. Set it to the same channel as the CH3/CH4 switch on the back of the VCP.

2

Insert a tape in the VCP. The power will come on and playback will start automatically. The POWER light will appear on the display panel of the VCP.

3

If the tape you want to play is already in the VCP, make sure the VCP power is on, then **press the PLAY button**.



Example of status symbol and counter during playback. See details below.

4

To stop playback, press the **STOP button**.

5

Press the **REW(ind) button**.

6

Press the **EJECT button** to eject the tape.

Status Symbols/Real-time Tape Counter

A status symbol and the real-time tape counter will appear on the TV screen for five seconds when you press certain function buttons (PLAY, FF, EJECT, etc.). Or, you may press the DISPLAY button on the remote control to see the status symbol or counter. The meaning of each status symbol is given here.

▶	PLAY
◀◀	REWIND
▶▶	FAST FORWARD
▲	EJECT
■	STOP

The counter shows the elapsed playing time of the tape from the point at which you set the counter to 0:00:00. The counter is automatically reset to 0:00:00 when you first insert a tape. If you want to refer to a particular point on a tape later, play the tape to that point. Then, press the COUNTER RESET button on the remote control to set the counter to 0:00:00 at that point. Later, when you are searching for that particular point, press the DISPLAY button so you can see the counter as you fast forward or rewind the tape to the 0:00:00 point.

1 Turn on the TV. Set it to channel 3 or 4.

2 Insert a tape in the VCP.

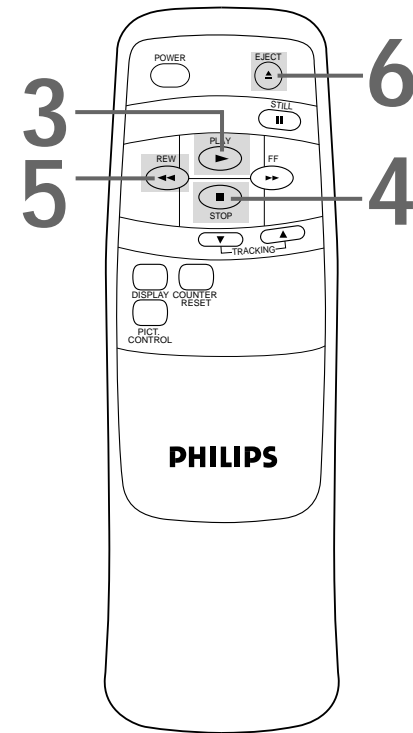

Helpful Hints

- Other playback options and features are explained on pages 17-20.
- Moisture may condense inside the unit when you move it from a cold place to a warm place, after heating a cold room, or when the humidity is high. When moisture accumulates in your VCP, the POWER light will blink on the VCP and the  symbol will appear on the TV screen. If you try to play a tape in a VCP in which moisture has accumulated, the tape and the VCP could be damaged. If the POWER light is blinking, keep the VCP power on (but do not play a tape) for at least two hours. When the POWER light stops blinking, it is safe to play a tape.

Repeat Playback 17

1

During tape playback, press the **AUTO REPEAT** button on the front of the VCP. The AUTO REPEAT light will appear on the VCP display panel. When a tape reaches the end, the VCP will rewind it and start playback again and again.

2

To cancel Repeat Playback, press the **AUTO REPEAT** button again. The AUTO REPEAT light will go off.

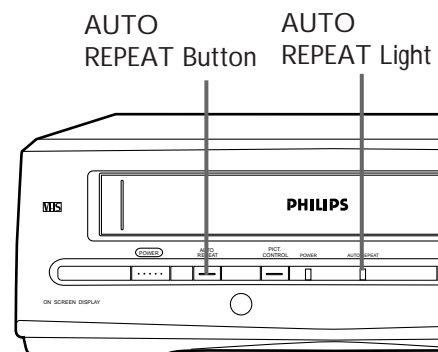

Helpful Hint

- If you press the **AUTO REPEAT** button to start Repeat Playback when playback is stopped, playback will start automatically. The **AUTO REPEAT** light will appear.

18 Picture Control

1

During tape playback, press the PICT(ure) CONTROL button on the front of the VCP or the remote control to change the picture quality of tapes. You can select SOFT, SHARP, or NORMAL.

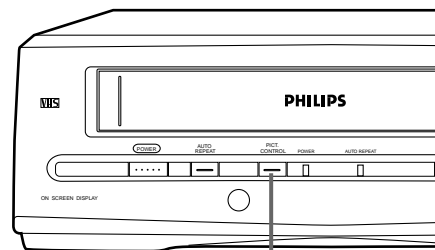
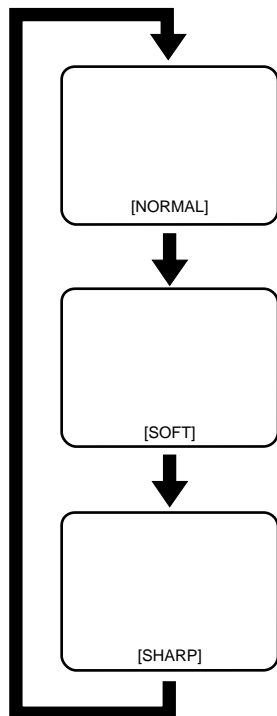

PICT(ure)
CONTROL Button

2

To turn off the Picture Control feature, press the PICT(ure) CONTROL button repeatedly until NORMAL appears.

Forward and Reverse Searching (SP/LP/SLP)

1

During tape playback, press and release the FF button or the REW(ind) button. A fast forward or reverse picture search will begin. (Noise bars will appear.)

2

To stop searching, press the STOP button. To return to playback, press the PLAY button.

Super High Speed Searching (LP/SLP)

1

During tape playback, press the FF button or the REW(ind) button, then press again. Now, the VCP will search in super high speed. (Noise bars will appear.) Press the FF button or the REW(ind) button repeatedly to switch between regular and super high speed searching.

2

To return to playback, press the PLAY button.

Viewing a Still Picture

1

During tape playback, press the STILL button. A still picture will appear on the screen. Tapes recorded in SLP (Super Long Play) will show the clearest still picture.

2

Each time you press the STILL button, the noise bars will change position on the screen. The tape also will advance slightly.

If a still picture vibrates vertically, stabilize it by pressing the TRACKING (▲/▼) buttons on the remote control.

3

To release the still picture and return to normal playback, press the PLAY button.

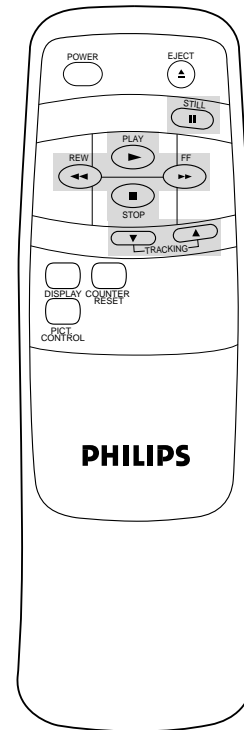

Helpful Hints

- SP/LP/SLP means this feature will work with tapes recorded in Standard Play, Long Play, or Super Long Play.
- LP/SLP means this feature will work with tapes recorded in Long Play or Super Long Play. For details about tape speed, see page five.
- Still mode automatically switches to Stop mode after five minutes to protect the VCP and the tape from damage.

20 Automatic Operation Features

Direct Button Operation

When a tape is in the VCP and the VCP power is off, press the PLAY, REW(ind), or F.FWD button **on the VCP**. The VCP will turn on automatically and playback, rewinding, or fast forwarding will start immediately.

Automatic Playback

When you put a tape in the VCP, the power will come on and playback will begin automatically.

Automatic Rewind, Off, Eject

When you play or fast forward a tape to its end, the VCP will rewind the tape, stop, turn itself off, and eject the tape. (The VCP will not operate this way if Repeat Playback is activated. *Details are on page 17.*)

Tape Eject

You can eject a tape with the VCP power on or off (but the VCP power cord must be plugged in).

Automatic Tracking Adjustment

The VCP has automatic tracking adjustment, which gives you the best possible picture quality. With some recordings, however, you may get a better picture using the manual tracking controls (see below).

Manual Tracking

To adjust the tracking manually during tape playback, press the TRACKING (▲/▼) buttons on the remote control.

NOTE:

- Tracking returns to automatic tracking adjustment when you insert a tape or press the STOP button to halt playback.

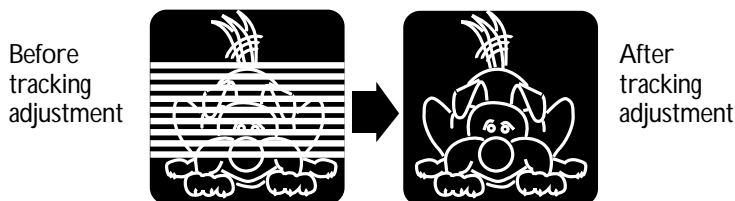

Antenna: VHF (very high frequency; channels 2 - 13) and UHF (ultra high frequency; channels 14 - 69).

AUDIO OUTPUT Jack: jack on the back of the VCP which is used to send audio to another system.

Cable: all standard channels can be received without a Cable Box. The cable box output channel usually is channel 03 or 04.

Frame: a single still picture.

Remote Control: the small electronic unit that came with your VCP; allows you to operate your VCP from a distance.

RF coaxial cable: The black cable supplied with your VCP. Use it to connect your VCP to your TV (or Cable Box). The supplied cable is a snap-on type. However, you may use a screw-on type if you prefer.

Special Effects: forward and reverse searching, viewing a still picture.

VCP: video cassette player.

VIDEO OUTPUT Jack: jack on the back of the VCP which is used to send video to another system.

22 *Helpful Hints*

If you are having problems with your product, check this list of problems and possible solutions before requesting service. You may be able to solve the problem yourself.

If you need to call a customer service representative, please know the model number and serial number of your product before you call. This information is on the back of the product. Also, please take a moment to identify the problem you are having, and be prepared to explain this to the representative. If you believe the representative will need to help you with operations, please stay near the product. Our representatives will be happy to assist you.

The VCP has no power.

- Connect the AC power cord to an AC (alternating current) outlet completely. If you are using AC power, disconnect the car battery cord completely.
- Connect the car battery cord completely to the vehicle's cigarette lighter socket and to the DC 13.2V jack on the back of the VCP when you are using the VCP in the vehicle.
- Make sure the power is on.

There is no playback picture, or the playback picture is noisy and contains streaks.

- Set the TV to the same channel as the VCP's CH3/CH4 switch.
Details are on pages six-nine.
- Adjust channel 3 or 4 properly at the TV.
- Adjust the tracking. *Details are on page 20.*
- TVs that are too close to the VCP can cause interference during tape playback. Move the VCP away from the TV.

The remote control will not operate the VCP.

- Aim the remote control directly at the VCP's remote sensor (page 14).
- Remove all obstacles between the remote control and the VCP.
- Inspect and/or replace the batteries in the remote control (page five).

You can not watch TV programs normally.

- Check the connections between the VCP, your TV, the Cable Box (if applicable), and the antenna/cable (pages six-10).
- Turn off the VCP power.

You can not insert a tape in the VCP.

- Insert the tape window side up, with the record tab facing you.
- Make sure a tape isn't already in the VCP by pressing the STOP/EJECT button on the VCP or the EJECT button on the remote control.
- Gently push on the center of the tape when putting it in the VCP. Never force the tape into the VCP.

You can not remove a tape from the VCP.

- Connect the AC power cord to an AC (alternating current) outlet completely. If you are using AC power, disconnect the car battery cord completely.
- Connect the car battery cord to the vehicle's cigarette lighter socket completely and to the DC 13.2V Jack on the back of the VCP when you are using the VCP in the vehicle.
- Unplug the VCP power cord for five minutes. Then, plug in the power cord again, then press the POWER button on the VCP. If the tape does not eject, press the STOP/EJECT button on the VCP three to five times. If the tape still does not eject, you may need to have an authorized servicer remove the tape.

The motor (cylinder) rotates even when the VCP is in Stop mode.

- To enable the quick play mechanism, the cylinder will rotate for about five minutes. This is normal. The quick play mechanism allows the tape mechanism to switch from Stop mode to Play mode in one second.

The playback picture is too dim, too bright, or fluctuates in brightness.

- Some programs may be broadcast with copyright protection technology in order to protect the rights of copyright owners. If you play a tape that is a recording of a copyright protected program, the picture may not be clear. The picture may be dark or dim, or the brightness of the picture may fluctuate. Avoid playing copies of copyright protected programs. This VCP incorporates copyright protection technology that is protected by method claims of certain U.S. patents and other intellectual property rights owned by Macrovision Corporation and other rights owners. Use of this copyright protection technology must be authorized by Macrovision Corporation and is intended for home and other limited viewing uses only, unless otherwise authorized by Macrovision Corporation. Reverse engineering or disassembly is prohibited.

The POWER light is blinking or the symbol appears on the TV screen.

- Moisture may condense inside the unit when you move it from a cold place to a warm place, after heating a cold room, or when the humidity is high. When moisture accumulates in your VCP, the POWER light will blink on the VCP and the  symbol will appear on the TV screen. If you try to play a tape in a VCP in which moisture has accumulated, the tape and the VCP could be damaged. If the POWER light is blinking, keep the VCP power on (but do not play a tape) for at least two hours. When the POWER light stops blinking, it is safe to play a tape.

24 Limited Warranty

VIDEO CASSETTE RECORDER or PLAYER

90 days Free Exchange / 91 days—One Year Reduced-Cost Exchange

WHO IS COVERED?

You must have proof of the date of purchase to exchange your product. A sales receipt or other document showing the date that you purchased the product is considered such proof.

WHAT IS COVERED?

Warranty coverage begins the day you buy your product. For 90 days thereafter, you may exchange the defective product for a new or renewed product at the store from which it was purchased or through Philips. Either exchange is made at no cost to you.

From 91 days to one year from the date of purchase, you must follow the exchange procedures set out on the next page. For an exchange during this warranty period you must pay \$29.95 (plus your local sales tax) for a new or renewed product. This reduced-cost exchange ends one year after the date of purchase.

The replacement product is covered only for the warranty period of the original product. When the warranty on the original product expires, the warranty on all replaced products also expires.

WHAT IS EXCLUDED?

Your warranty does not cover:

- shipping charges to return defective product.
- labor charges for installation or setup of the product, adjustment of customer controls on the product, and installation or repair of antenna systems outside of the product.
- product repair and/or part replacement because of improper installation, abuse, neglect, misuse, accident, unauthorized repair or other cause not within the control of Philips Consumer Electronics.
- reception problems caused by signal conditions or cable or antenna systems outside the product.
- a product that requires modification or adaptation to enable it to operate in any country other than the country for which it was designed, manufactured, approved and/or authorized, or repair of products damaged by these modifications.
- incidental or consequential damages resulting from the product. (Some states do not allow the exclusion of incidental or consequential damages, so the above exclusion may not apply to you. This includes, but is not limited to, prerecorded material, whether copyrighted or not copyrighted.)
- damage caused by the use of non-VHS tapes or tapes that have not been tested and labeled for use in two, four, six, and eight hour VHS recorders.
- a product that is used for commercial or institutional purposes (including but not limited to rental purposes).

WHERE IS EXCHANGE AVAILABLE?

Warranty exchange is available in all countries where the product is officially distributed by Philips Consumer Electronics. In countries where Philips Consumer Electronics does not distribute the product, the local Philips service organization will attempt to exchange the product, although there may be a delay if the appropriate product is not readily available.

MAKE SURE YOU KEEP...

Please keep your sales receipt or other document showing proof of date of purchase. Attach it to the owner's manual and keep both nearby. Also keep the original box and packing material in case you need to return your product.

BEFORE EXCHANGING THE PRODUCT...

Please check your owner's manual before exchanging the product. Adjustments of the controls discussed there may save you time and money.

LIMITATION OF LIABILITY AND REMEDY...

Philips is not liable under any circumstances for any direct, indirect, special, incidental, or consequential damages, howsoever incurred, even if notified of the possibility of such damages.

To the extent permitted by local law, the remedies provided in this warranty statement are your sole and exclusive remedy.

This limited warranty gives you specific legal rights, and you may also have other rights which vary from state/province to state/province.

TO EXCHANGE YOUR PRODUCT IN THE U.S.A., PUERTO RICO, OR U.S. VIRGIN ISLANDS...

Follow the instructions stated previously in the "What is Covered" section, or refer to the exchange instructions on the next page.

In the U.S.A., Puerto Rico, and U.S. Virgin Islands, all implied warranties, including the implied warranties of non-infringement, merchantability and fitness for a particular purpose, are specifically disclaimed, and to the extent inconsistent with law of the locality of the user, limited in duration to the duration of this express warranty. Because some states do not allow limitations on how long an implied warranty may last, this limitation may not apply to you.

TO EXCHANGE A PRODUCT IN CANADA...

Please contact Philips at:

1-800-661-6162 (French Speaking)

1-800-363-7278 (English Speaking)

In Canada, this warranty is given in lieu of all other warranties. There are no other warranties, express or implied, including any implied warranties of merchantability or fitness for a particular purpose.

TO GET OUT-OF-WARRANTY EXCHANGE...

In the U.S.A., Puerto Rico, or U.S. Virgin Islands, contact Philips Service Solutions Group at 1-800-531-0039 to obtain the cost of out-of-warranty exchange.

REMEMBER...

Please record below the model and serial numbers found on the product. Also, please fill out and mail your warranty registration card promptly. It will be easier for us to notify you if necessary.

MODEL # _____

SERIAL # _____

Limited Warranty (cont'd) 25

EXCHANGE INSTRUCTIONS

If your product is defective, you may be able to exchange it at the store from which it was purchased. Most stores display a Return Policy. If not, ask the manager or sales associate how many days you have to exchange a product with them. After the store's return period has expired, or if the store does not have an exchange program, you may exchange the product with Philips if you have your original sales receipt.

To exchange your product with Philips (per the warranty conditions stated previously), remember:

- If you exchange the product within 90 days of the original purchase, there is no cost to you.
- If you exchange the product more than 90 days after but less than one year after the day of original purchase, your cost will be \$29.95 plus your local sales tax. If sales tax is missing or incorrect, your order will be delayed, and you will be contacted.
- After 12 months from the day of original purchase, contact Philips Service Solutions Group (PSSG) at 1-800-531-0039 for information regarding out-of-warranty exchange.
- If you do not have your original sales receipt, or if you have any questions, call PSSG at 1-800-531-0039.

To obtain a replacement product from Philips:

1. Complete the Exchange Form below.
2. Pack the product and its accessories (remote control, rf coaxial cable, owner's manual, and car battery cord, if applicable) in the original box or a suitable alternative. You will receive replacement accessories with your replacement product. For packing details, call 1-800-531-0039.
3. Put the completed Exchange Form, a copy of the original sales receipt, and the proper payment amount into an envelope. DO NOT SEND CASH. Do not staple or clip these items together. Label the envelope "Return Documents Enclosed." Place this envelope in the box with the product.
4. Seal the box with packing tape and return the product via United Parcel Service (UPS), insured and freight pre-paid, to:

Philips Recovery Center
Rojas 6
12420 Mercantile Avenue
El Paso, TX 79928
ATTENTION: VCR EXCHANGE

A replacement will be sent to you via UPS within 48 business hours of Philips' receipt of the product.

EXCHANGE FORM

Your Address (street address to which replacement should be delivered, no P.O. boxes allowed):

Name: _____

Street Address: _____

Apt. #: _____

City: _____

State/Province: _____

Zip Code/Postal Code: _____

Phone (day): _____

Phone (night): _____

Payment Amount: \$29.95 + Sales Tax _____ = Total _____

Method of Payment: (Check one. Please, no cash or CODs.)

_____ Check/Money order Check/Money order number _____

_____ American Express Account number _____ Expiration date _____

_____ Visa _____ _____

_____ Novus/Discover _____ _____

_____ Mastercard _____ _____

Signature: _____

Detailed reason for return, use additional paper if necessary: _____

Model Number _____ Serial Number _____

Remember, the return box should include the following:

- The product,
- Completed Exchange Form and sales receipt,
- Accessories supplied with the product, and
- Payment, if applicable.

26 Specifications

Video Heads

Two heads

Video Signal

EIA standards; NTSC color

Antenna

VHF/UHF – 75 ohm external antenna/cable terminal

VHF Output Signal

Channel 3 or 4 (switchable)

75 ohms unbalanced

Power Requirement

AC 120V \pm 10%, 60Hz \pm 5%,

DC 13.2V \pm 10%

Power Consumption

AC 12W

DC 10W

Operating Temperature

41°F (5°C) to 104°F (40°C)

Relative Humidity

10% to 80%

Weight

4.4 lbs. (2.0 kg.)

Dimensions

11"(W) x 3-5/8"(H) x 9-27/32"(D)

(280 mm x 92mm x 250mm)

NOTE: Designs and specifications are subject to change without notice.

ac power cord	15	power	
accessories	28	button	12, 14
ant(enna) in jack	15	cord	15
ant(enna) out jack	15	light	13
audio output jack	10, 15	rear panel	15
automatic		remote control	
playback	20	buttons	12
rewind, off, eject	20	using	5
auto repeat		remote sensor	5, 14
button	14	repeat playback	17
light	13	rew(ind) button	12, 14
batteries	5	rf coaxial cable	6-9
car battery cord	11	safety precautions	3
cassette compartment	13	searching	19
ch3/ch4 switch	7-9, 15	sensor (remote)	5, 14
connections	6-11	slp	5, 19
contents, table of	4	sp	5, 19
controls		standard play	5, 19
remote	12	stereo tv hookup	10
vcp	13-15	still button	12, 19
counter reset button	12, 16	still picture	19
DC 13.2v jack	11, 15	stop button	12
dew sensor	13, 16	stop/eject button	14
direct button operation	20	super high speed searching	19
display button	12	super long play	5, 19
display panel	13	table of contents	4
eject button	12	tape	
ejecting a tape	20, 23	eject	20, 23
f.fwd button	14	speeds	5
ff button	12	tracking	20
front panel	14	tracking (▲/▼) buttons	12, 19-20
glossary	21	tv hookups	6-11
helpful hints	22-23	vertical jitter	19
hookups		video output jack	10, 15
mobile	11	video tapes (<i>see tape</i>)	
with a cable box	8-9	warranty	24-25
with a stereo tv	10		
without a cable box	6-7		
long play	5, 19		
lp	5, 19		
pict(ure) control button	12, 14		
picture control	18		
play button	12, 14		
playback features	17-20		
playing a tape	16		

SUPPLIED ACCESSORIES

The following items are supplied with your VCP; they are provided to help you use or set up your VCP.

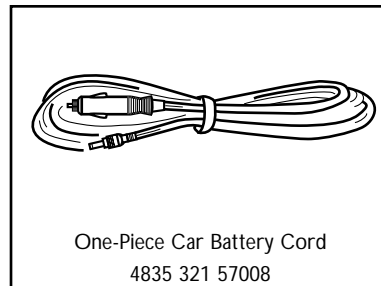
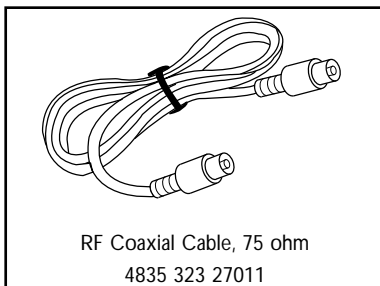
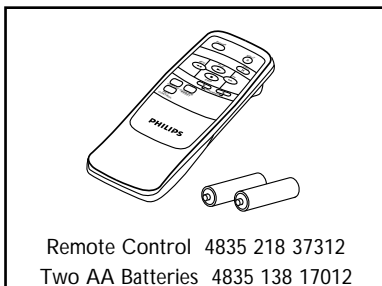

OPTIONAL ACCESSORIES

The following additional items are not provided with your VCP, but they are designed for use with your new VCP. To order these optional accessories, contact us at:

**Philips Parts & Accessories Marketing Department
401 East Old Andrew Johnson Highway
P.O. Box 555
Jefferson City, TN 37760
1-800-851-8885.**

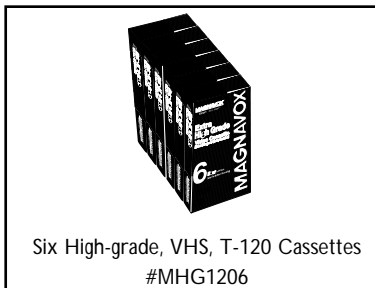
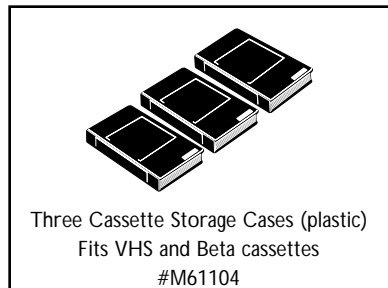
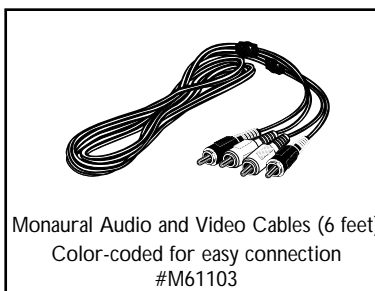

This owner's manual is made of recyclable materials.
Remember to recycle!

IB8285E002
Printed In China
0VMN02650 / H75A0UD* * * * *